

RESOLUTION NO. 22-11-120

A RESOLUTION OF THE VILLAGE COUNCIL OF ISLAMORADA, VILLAGE OF ISLANDS, FLORIDA, APPROVING CHANGE ORDER NO. 1 TO THE AGREEMENT BETWEEN ISLAMORADA, VILLAGE OF ISLANDS AND AQUA WASTE REPAIRS, INC. RELATED TO THE CANAL 114 INJECTION WELL RESTORATION PROJECT; AUTHORIZING THE VILLAGE OFFICIALS TO IMPLEMENT THE TERMS AND CONDITIONS OF CHANGE ORDER NO. 1; AUTHORIZING THE VILLAGE MANAGER TO EXPEND BUDGETED FUNDS AND PROVIDING FOR AN EFFECTIVE DATE

WHEREAS, on September 21, 2022, Islamorada, Village of Islands (the "Village"), entered into an Agreement with Aqua Waste Repairs Inc. (the "Contractor") for the installation of the Plantation Key Canal 114 Gravity Injection Well as part of a canal restoration project; and

WHEREAS, Article 10.1 "Change to Scope of Work and Additional Work" of the Agreement provides for changes, modifications, and additions to the Agreement; and

WHEREAS, in October 2022, the Contractor presented Village staff with Change Order #1 for the substitution of a 24 inch diameter gate valve with wheel crank to a 30 inch diameter gate valve with 2 inch square nut with T-handle wrench; and

WHEREAS, Change Order No. 1 provides for changes to the Scope of Services to reflect this substitution of parts; and

WHEREAS, the Village Council finds that approval of Change Order No. 1 to the Agreement between the Village and the Contractor is in the best interest of the Village.

NOW THEREFORE, BE IT RESOLVED BY THE VILLAGE COUNCIL OF ISLAMORADA, VILLAGE OF ISLANDS, FLORIDA, AS FOLLOWS:

Section 1. Recitals. The above recitals are true and correct and incorporated into this Resolution by this Reference.

Section 2. Approval of Change Order. The Village Council of Islamorada, Village of

Islands, hereby approves Change Order No. 1 between the Village and the Contractor, a copy of which is attached hereto as Exhibit "A", together with such non-material changes as may be acceptable to the Village Manger and approved as to form and legality by the Village Attorney.

Section 3. Authorization of Village Officials. The Village Manager or designee and the Village Attorney are authorized to take all necessary and expedient action to implement the terms and conditions of Change Order No. 1.

Section 4. Authorization of Fund Expenditure. Notwithstanding the limitations imposed upon the Village Manager pursuant to the Village's Purchasing Procedures Ordinance, the Village Manager is authorized to expend budgeted funds to implement the terms and conditions of Change Order No. 1.

Section 5. Execution of Change Order. The Village Manager is authorized to execute Change Order No. 1 on behalf of the Village, to execute any required agreements and/or documents to implement the terms and conditions of Change Order No. 1 and to authorize any further acts necessary to implement the terms thereof, subject to approval as to form and legality by the Village Attorney.

Section 6. Effective Date. This Resolution shall become effective immediately upon its adoption.

Motion to adopt by K YVV, seconded by ; fY[[.

FINAL VOTE AT ADOPTION

VILLAGE COUNCIL OF ISLAMORADA, VILLAGE OF ISLANDS

Mayor Pete Bacheler	<u>Ng</u>
Vice Mayor Henry Rosenthal	<u>Ng</u>
Councilman Mark Gregg	<u>Ng</u>
Councilman Buddy Pinder	<u>Ng</u>
Councilman David Webb	<u>Ng</u>

PASSED AND ADOPTED THIS 17th DAY OF NOVEMBER, 2022.



PETE BACHELER, MAYOR

ATTEST:

MARNE MCGRATH, VILLAGE CLERK

APPROVED AS TO FORM AND LEGALITY
FOR THE USE AND BENEFIT OF
ISLAMORADA, VILLAGE OF ISLANDS:



JOHN J. QUICK, INTERIM VILLAGE ATTORNEY

EXHIBIT "A"

CHANGE ORDER NO. 1

VILLAGE/OWNER: Islamorada, Village of Islands

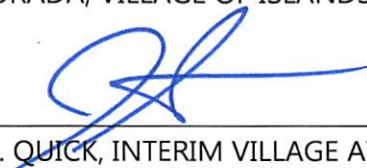
COMPANY: Aqua Waste Repairs, Inc.

PROJECT: Canal 114 Restoration Gravity Injection Well

DATE: November 17, 2022

This Change Order will authorize the following changes to the Agreement:

The construction work as set forth in the Agreement is hereby amended as set forth in Exhibit "A" attached hereto and by this reference made a part hereof for all purposes.

This Change Order constitutes full, final, and complete compensation to the Company for all costs, expenses, overhead, and profit that the Company may incur in connection with the above referenced changes to the Agreement, and any other effect on any of the work under the Agreement. The Company acknowledges and agrees that the Agreement Price as reflected in the Agreement will be changed by this Change Order and (b) the Project Schedule and Contract Time for completion of the Canal 114 Injection Well will be unchanged by this Change Order. Except as herein or heretofore expressly modified, all terms of the Agreement shall remain in full force and effect and shall cover the performance of, and payment for, any changes in the construction work authorized hereunder. Any defined terms not defined in this Change Order shall have the meanings set forth in the Agreement.

By signing below the parties indicate acceptance of this Change Order as set forth herein.

[Signatures Follow on the Next Page]

Change Order No. 1

Page 2 of 2

VILLAGE/OWNER

ISLAMORADA, VILLAGE OF ISLANDS

By: [Signature]
Name: Ted Yates
Title: Village Manager

Date Executed: 11/18/22

ATTEST:

[Signature]

Village Clerk

Approved as to form and legal sufficiency for
the use and benefit of Islamorada, Village of
Islands:

[Signature]

Village Attorney

COMPANY:

AQUA WASTE REPAIRS INC.

By: [Signature]
Name: Paula R. Sutton
Title: Controller

Date Executed: 11/21/22



CHANGE ORDER #1

ITEM	QUANTITY	SIZE	UNIT PRICE	AMOUNT	COST/CHANGE TO CONSTRUCTION CONTRACT
<p align="center">ADDED TO SCOPE</p> <p>ALUMINIUM FLATBACK CANAL GATE, WATERMAN MODEL AC-31-F-NRS (FRAME FLATBACK ALUMINIUM B-209 AL.6061 T6, GATE MOUNTED ON GROUT PAD (BY OTHERS), FRAME SEAL NEOPRENE, COVER ALUMINIUM B-209 AL6061-T6, GATE SEATS UHMW, MINIMUM HEIGHT FRAME H=59", LIFT & STEM BASED ON OPERATING HEADS 6.33' SEATING & UNSEATING, 304SS STEM, NON RISING STEM, 2" SQUARE NUT, T- HANDLE WRENCH, 304SS MOUNTING HARDWARE)</p>	1	30"	\$12,487.06 /EA	\$12,487.06 + \$850.00 FREIGHT	\$13,337.06
<p align="center">DELETED FROM SCOPE</p> <p>ALUMINIUM FLATBACK CANAL GATE, WATERMAN MODEL AC-31-F-NRS (FRAME FLA IBA CK ALUMINIUM B 209 AL.6061 T6, GATE MOUNTED ON GROUT PAD (BY OTHERS), FRAME SEAL NEOPRENE, COVER ALUMINIUM B-209 AL6061-T6, GATE SEATS UHMW</p>	1	24"	\$7,079.64 /EA	\$7,079.64 + \$750.00 FREIGHT	(\$7,829.64)
<p align="center">TOTAL NET CHANGE</p>					\$5,507.42

Exhibit "1"

AIA DOCUMENT G701-2000



Change Order

(Instructions on reverse side)

PROJECT:
(Name and address)
CANAL 114 INJECTION WELL
RFP 22-06

CHANGE ORDER NUMBER: 0001
DATE: October 17, 2022
ARCHITECT'S PROJECT NUMBER: 6783-19-3137
CONTRACT DATE: September 21, 2022
CONTRACT FOR: GRAVITY INJECTION WELL

OWNER []
ARCHITECT []
CONTRACTOR []
FIELD []
OTHER []

TO CONTRACTOR:
(Name and address)
AQUA WASTE REPAIRS, INC.
3575 SNEED ROAD
FORT PIERCE, FL 34945
772-461-6228

THE CONTRACT IS CHANGED AS FOLLOWS:
(Include, where applicable, any undisputed amount attributable to previously Executed Construction Change Directives.)

Change from 24" diameter gate valve, with wheel crank to 30" diameter gate valve with 2" square nut with T-handle wrench.

Price increase \$5,507.42

The original (Contract Sum) (Guaranteed Maximum Price) was \$ 268,905.00
The net change by previously authorized Change Orders \$
The (Contract Sum) (Guaranteed Maximum Price) prior to this Change Order was \$ 268,905.00
The (Contract Sum) (Guaranteed Maximum Price) will be (increased) (decreased)
(increased) by this Change Order in the amount of \$ 5,507.42
The new (Contract Sum) (Guaranteed Maximum Price) including this Change Order will be \$ 274,412.42
The Contract Time will be (increased) (decreased) (unchanged) by () () days.
The date of Substantial Completion as of the date of this Change Order therefore is

NOTE: This Change Order does not include changes in the Contract Sum, Contract Time or Guaranteed Maximum Price which have been authorized by Construction Change Directive for which the cost or time are in dispute as described in Subparagraph 7.3.8 of AIA Document A201.

Not valid until signed by the Architect, Contractor and Owner.

ENGINEER STEPHEN HANKS
ARCHITECT (Typed name)

AQUA WASTE REPAIRS, INC.
CONTRACTOR (Typed name)

ISLAMORADA, VILLAGE OF IS
OWNER (Typed name)



© 2000 AIA ©
AIA DOCUMENT G701-2000
CHANGE ORDER

(Signature)

(Signature)

(Signature)

BY

BY

BY

DATE

DATE

DATE



wood.
 ENVIRONMENT &
 INFRASTRUCTURE
 5845 NW 158TH STREET
 MIAMI LAKES, FL 33014
 TEL: (305) 826-5888

ENGINEER OF RECORD
 STEPHEN HANNA
 FL PE #72253

PROJECT:
 CANAL #14 PLANTATION KEY
 GRADUATION SECTION WELL
 FINAL DESIGN

APPLICANT:



WOOD PROJECT No.
 0723-13-2127

NO.	DATE	BY	APPROVED

DESIGNED BY:	SM/CWC
DRAWN BY:	LONG
CHECKED BY:	SM
APPROVED BY:	JK
DATE:	1/27/2023

SHEET TITLE:
 PROPOSED
 DETAILS

SHEET NUMBER:	C300
REV. #	
SHEET 5 OF 5 SHEETS	

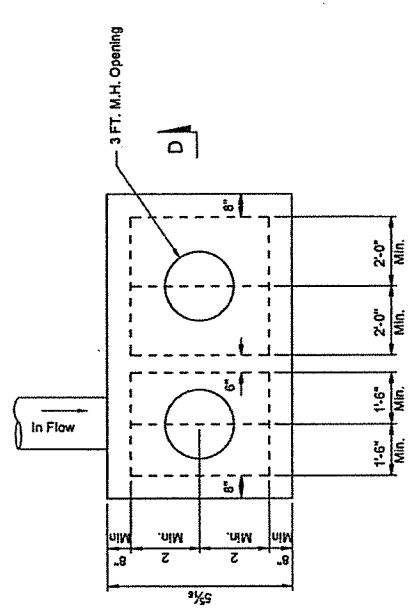

PLAN VIEW

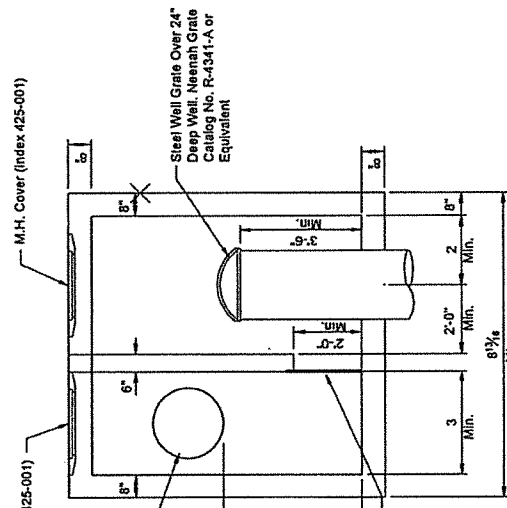

DETAIL D-D

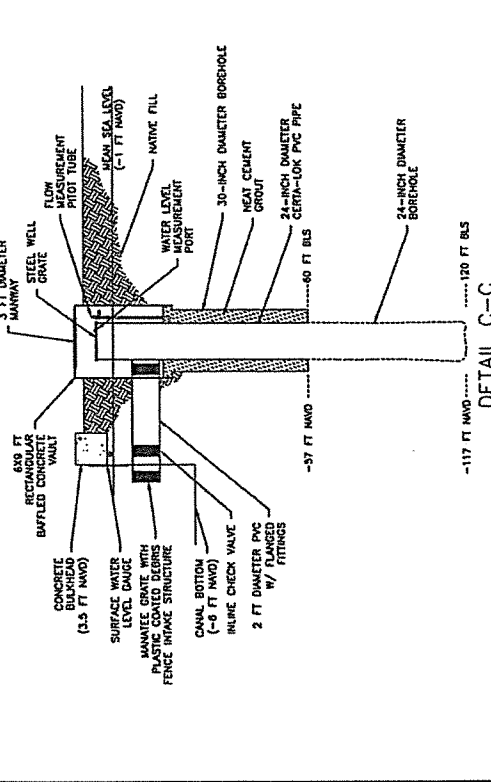

DETAIL C-C

Perforated 304 Stainless Steel plate; 1 1/2 gauge with with 3/8" holes on 9/16" centers. To be connected to lower baffle with 3/4" diameter galvanized expansion bolt with nut and washer. The plate shall have an extended 2" inch angle band that sits flush to the bottom and sides of the manhole.

NOTES:
 1) THE ELEVATIONS ARE BASED ON THE MAY 20, 2020 SURVEY COMPLETED UNDER MIAMI ENGINEERING SERVICES AND THE NOVEMBER 2020 SITE PLAN.
 2) THE TIDE LEVELS ARE BASED ON NOAA STATION ID 8723789 IN PLANTATION KEY, FLORIDA.

C/S 1
 pg 1 of 4

cls1
pg 2 of 4

McDade

Waterworks, Inc.

6520 Harney Road - Tampa, FL 33610
 Post Office Box 16039 - Tampa, FL 33687-6039
 (813) 740-1144 - FAX (813) 627-9387

Serving the Water & Wastewater Plant Industry for over 30 Years

To:	AQUA WASTE REPAIRS	Fax:	
Attn:	PAULA R. SUTTON	Phone:	
Subject:	CANAL 114 GRAVITY WELL	Date:	AUGUST 4, 2022
From:	WESLEY BUNN	Quote #:	

Terms	F.O.B.	Freight	Ship Via	Validity
Net 30	Factory	Freight Included	Best Way	30 Days

LINE #	Quantity	Size	Description	Unit Price	Total	Lead Time
01	1	24"	ALUMINUM FLATBACK CANAL GATE, WATERMAN MODEL AC-31-F-NRS (FRAME FLATBACK ALUMINUM B-209 AL.6061 T6, GATE MOUNTED ON GROUT PAD (BY OTHERS), FRAME SEAL NEOPRENE, COVER ALUMINUM B-209 AL6061-T6, GATE SEATS UHMW	7,079.64	7,079.64	
02						
03						
04						
05						
06						
07						
08						
09						
10						
11						
12						
13						
14						
15						
16						
17						
18						
19						
20						
21						
22						
23						
24						
25						
26						
27						
28						
29						

Sub-Total:	7,079.64
Freight:	750.00
TOTAL:	7,829.64

Sales Tax NOT Included

All Material Subject to Prior Sale

McDade Waterworks, Inc. reserves the right to apply "Price in Effect" at time of delivery due to shortages and/or further tariff declarations by state or federal agencies. McDade Waterworks Inc. will not be responsible for industry price changes or shortages beyond our control as a result of changes to the current tariff law.

This quotation is for your acceptance in its entirety within 30 Days. If quantities or descriptions should change, McDade Waterworks, Inc. reserves the right to submit a revised quotation.

Sincerely,
 McDade Waterworks, Inc.

Wesley G. Bunn, VP

McDade

Waterworks, Inc.

6520 Harney Road - Tampa, FL 33610
 Post Office Box 16039 - Tampa, FL 33687-6039
 (813) 740-1144 - FAX (813) 627-9387

Serving the Water & Wastewater Plant Industry for over 30 Years

To: AQUA WASTE REPAIRS	Fax:
Attn: PAULA R. SUTTON	Phone:
Subject: CANAL 114 GRAVITY WELL	Date: September 29, 2022
From: WESLEY BUNN	Quote #:

Terms: Net 30	F.O.B.: Factory	Freight: Freight Included	Ship Via: Best Way	Validity: 30 Days
----------------------	------------------------	----------------------------------	---------------------------	--------------------------

LINE #	Quantity	Size	Description	Unit Price	Total	Lead Time
01	1	30"	ALUMINUM FLATBACK CANAL GATE, WATERMAN MODEL AC-31-F-NRS (FRAME FLATBACK ALUMINUM B-209 AL.6061 T6, GATE MOUNTED ON GROUT PAD (BY OTHERS), FRAME SEAL NEOPRENE, COVER ALUMINUM B-209 AL6061-T6, GATE SEATS UHMW, MINIMUM HEIGHT FRAME H=59", LIFT & STEM BASED ON OPERATING HEADS 6.33' SEATING & UNSEATING, 304SS STEM, NON RISING STEM, 2" SQUARE NUT, T-HANDLE WRENCH, 304SS MOUNTING HARDWARE)	12,487.06	12,487.06	
02						
03						
04						
05			IF YOU CAN PURCHASE MORE THAN ONE AT A TIME WE CAN POSSIBLY GET SOME BETTER PRICING.			
06						
07						
08						
09						
10						
11						
12						
13						
14						
15						
16						
17						
18						
19						
20						
21						
22						
23						
24						
25						
26						
27						
28						
29						

Sub-Total:	12,487.06
Freight:	9.50
TOTAL:	12,487.06

Sales Tax NOT Included

All Material Subject to Prior Sale

McDade Waterworks, Inc. reserves the right to apply "Price in Effect" at time of delivery due to shortages and/or further tariff declarations by state or federal agencies. McDade Waterworks Inc. will not be responsible for industry price changes or shortages beyond our control as a result of changes to the current tariff law.

This quotation is for your acceptance in its entirety within 30 Days. If quantities or descriptions should change, McDade Waterworks, Inc. reserves the right to submit a revised quotation.

Sincerely,
 McDade Waterworks, Inc.

Wesley G. Bunn, VP

13,337.06

+ 850 At

C/O 1
 pg 3 of 4

awrinc@hotmail.com

C/O 1
Pg 4 of 4

From: Wesley Bunn <wgbunn@MCDADEWATERWORKS.COM>
Sent: Monday, October 17, 2022 9:33 AM
To: AQUA WASTE REPAIRS, INC **
Subject: RE: WATERMAN AC-31

Estimated Freight is about \$850

Thank you,



Wesley G. Bunn V.P.
Main Office Phone: (813) 740-1144
Cellular Phone: (813) 376-0057
Fax: (813) 627-9387

E-Mail: wgbunn@mcdadewaterworks.com Web: <http://www.mcdadewaterworks.com>
Mailing: P.O. Box 16039 - Tampa, FL 33687-6039 Physical: 6520 Harney Road - Tampa FL. 33610

From: AQUA WASTE REPAIRS, INC ** <awrinc@hotmail.com>
Sent: Monday, October 17, 2022 9:25 AM
To: AQUA WASTE REPAIRS, INC ** <awrinc@hotmail.com>; Wesley Bunn <wgbunn@MCDADEWATERWORKS.COM>
Subject: RE: WATERMAN AC-31

Wes, good morning

Any idea the freight cost?

Respectfully yours,
Paula R. Sutton, Controller



Aqua Waste Repairs, Inc...

Water Well -Develop, Maintenance & Abandonment
Waste Water Equipment Sales & Installation
Temporary Bridge & Structural Shoring
3575 Sneed Road, Ft. Pierce, FL 34945
(O) 772-461-6228 (F) 772-461-6668
FL CGC# 1507436 WWC# 11329
WWW.AQUAWASTEREPAIRS.COM

APPLICATION AND CERTIFICATE FOR PAYMENT AIA DOCUMENT G702 (Instructions on reverse side) PAGE ONE OF 2 PAGES

TO ISLAMORADA VILLAGE OF ISLANDS PROJECT: CANAL 114 INJECTION WELL APPLICATION NO.: 02 Distribution to:
 86800 OVERSEAS HIGHWAY RFP 22-06 PERIOD TO: 11/21/2022 OWNER
 ISLAMORADA, FL 33036 PROJECT NOS.: CANAL 114 ARCHITECT
 CONTRACTOR

FROM AQUA WASTE REPAIRS, INC. VIA ARCHITECT: ENGINEER STEPHEN HANKS CONTRACT DATE: 9/21/2022
 3575 SNEED ROAD WOOD ENVIRONMENT & INFRASTRUCTURE SOLUTIONS
 FORT PIERCE, FL 34945
 772-461-6228

CONTRACT FOR: GRAVITY INJECTION WELL

CONTRACTOR'S APPLICATION FOR PAYMENT

Application is made for payment, as shown below, in connection with the Contract. Continuation Sheet, AIA Document G703, is attached.

1. ORIGINAL CONTRACT SUM\$ 268,905.00
2. Net change by Change Orders\$ 5,507.42
3. CONTRACT SUM TO DATE (Line 1 ± 2)\$ 274,412.42
4. TOTAL COMPLETED & STORED TO DATE\$ 114,277.09
(Column G on G703)
5. RETAINAGE:
 - a. _____% of Completed Work\$ _____
(Columns D + E on G703)
 - b. _____% of Stored Material\$ _____
(Column F on G703)
 Total Retainage (Line 5a + 5b or Total in Column I of G703)\$ _____
6. TOTAL EARNED LESS RETAINAGE\$ 114,277.09
(Line 4 less Line 5 Total)
7. LESS PREVIOUS CERTIFICATES FOR PAYMENT
(Line 6 from prior Certificate)\$ 108,769.67
8. CURRENT PAYMENT DUE\$ 5,507.42
9. BALANCE TO FINISH, INCLUDING RETAINAGE
(Line 3 less Line 6)\$ 160,135.33

CHANGE ORDER SUMMARY	ADDITIONS	DEDUCTIONS
Total changes approved in previous months by Owner	5,507.42	
Total approved this Month		
TOTALS	5,507.42	
NET CHANGES by Change Order		5,507.42

The undersigned Contractor certifies that to the best of the Contractor's knowledge, information and belief the Work covered by this Application for Payment has been completed in accordance with the Contract Documents, that all amounts have been paid by the Contractor for Work for which previous Certificates for Payment were issued and payments received from the Owner, and that current payment shown herein is now due.

CONTRACTOR: AQUA WASTE REPAIRS, INC.

By: [Signature] Date: 11/21/22

State of: FLORIDA
 County of: ST. LUCIE

Subscribed and sworn to before me this 21st day of Nov, 2022

Notary Public: [Signature]
 My Commission expires: 11/9/23

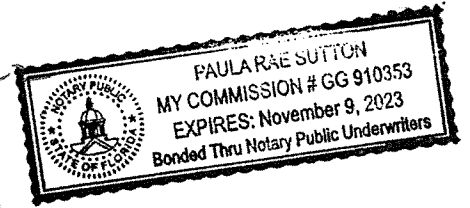

ARCHITECT'S CERTIFICATE FOR PAYMENT

In accordance with the Contract Documents, based on on-site observations and the data comprising this application, the Architect certifies to the Owner that to the best of the Architect's knowledge, information and belief the Work has progressed as indicated, the quality of the Work is in accordance with the Contract Documents, and the Contractor is entitled to payment of the AMOUNT CERTIFIED.

AMOUNT CERTIFIED\$ _____

(Attach explanation if amount certified differs from the amount applied for. Initial all figures on this Application and on the Continuation Sheet that are changed to conform to the amount certified.)

ARCHITECT: ENGINEER STEPHEN HANKS

By: _____ Date: _____

This Certificate is not negotiable. The AMOUNT CERTIFIED is payable only to the Contractor named herein. Issuance, payment and acceptance of payment are without prejudice to any rights of the Owner or Contractor under this Contract.



CONTINUATION SHEET

AIA DOCUMENT G703 (Instructions on reverse side)

AIA Document G702, APPLICATION AND CERTIFICATE FOR PAYMENT, containing Contractor's signed Certification, is attached.

In tabulations below, amounts are stated to the nearest dollar.

Use Column I on Contracts where variable retainage for line items may apply.

APPLICATION NO.: 02

APPLICATION DATE: 11/21/2022

PERIOD TO: 11/21/2022

ARCHITECT'S PROJECT NO.: 6783-19-3137

A ITEM NO.	B DESCRIPTION OF WORK	C SCHEDULED VALUE	D WORK COMPLETED		F MATERIALS PRESENTLY STORED (NOT IN D OR E)	G		H BALANCE TO FINISH (C - G)	I RETAINAGE (IF VARIABLE) RATE
			FROM PREVIOUS APPLICATION (D + E)	THIS PERIOD		TOTAL COMPLETED AND STORED TO DATE (D+E+F)	% (G ÷ C)		
10.001	MOB/DE-MOBILIZATION	39,500.00	3,950.00			3,950.00	10	35,550.00	
10.002	24" WELL	72,000.00	10,800.00			10,800.00	15	61,200.00	
10.003	VAULT	72,000.00	47,520.00			47,520.00	66	24,480.00	
10.004	INLINE CHECK VALVE	20,400.00	11,016.00			11,016.00	54	9,384.00	
10.005	GATE VALVE	16,800.00	14,280.00			14,280.00	85	2,520.00	
10.006	MANATEE GRATE/PIPE	14,400.00	7,920.00			7,920.00	55	6,480.00	
10.007	BOLLARDS/TEMP GRATES	15,000.00	9,900.00			9,900.00	66	5,100.00	
10.008	TURBIDITY	6,000.00						6,000.00	
10.009	Contingency POL INS	12,805.00	3,383.67			3,383.67	26	9,421.33	
20.001	CO#1 Canal Gate Increase	5,507.42		5,507.42		5,507.42	100		
		274,412.42	108,769.67	5,507.42		114,277.09	42	160,135.33	